



# Magnocellular Visual Function and Children's Single Word Reading

P. L. CORNELISSEN,\*† P. C. HANSEN,‡ J. L. HUTTON,† V. EVANGELINO,\* J. F. STEIN‡

Received 13 November 1996; in revised form 2 April 1997

Recent research has shown that reading disabled children find it unusually difficult to detect flickering or moving visual stimuli, consistent with impaired processing in the magnocellular visual stream. Yet, it remains controversial to suggest that reduced visual sensitivity of this kind might affect children's reading. Here we suggest that when children read, impaired magnocellular function may degrade information about where letters are positioned with respect to each other, leading to reading errors which contain sounds not represented in the printed word. We call these orthographically inconsistent nonsense errors "letter" errors. To test this idea we assessed magnocellular function in a sample of 58 unselected children by using a coherent motion detection task. We then gave these children a single word reading task and found that their "letter" errors were best explained by independent contributions from motion detection (i.e., magnocellular function) and phonological awareness (assessed by a spoonerism task). This result held even when chronological age, reading ability, and IQ were controlled for. These findings suggest that impaired magnocellular visual function, as well as phonological deficits may affect how children read. © 1998 Elsevier Science Ltd. All rights reserved.

Dyslexia Reading Magnocellular Coherent motion

## INTRODUCTION

Despite adequate educational opportunity, many children fail to acquire competent reading skills. A surprising number of these poor readers produce normal or above normal scores on IQ tests, so their reading problems are unexpected and they may be described as reading disabled (Rutter & Yule, 1975). The conventional explanation for the reading problems experienced by reading disabled children is that they are caused by a phonological deficit (Bradley & Bryant, 1983) in which "fuzzy" or "underspecified" phonological representations lead to difficulties with mapping letters onto sounds (Brady & Shankweiler, 1991). Consequently, reading disabled people often find it particularly hard to read nonsense words (Snowling, 1980).

Research in the last 15 years has also shown that both children and adults who are reading disabled perform differently from controls in a variety of low-level visual tasks (Willows, Kruk, & Corcos, 1993). Of interest are the functional MRI (Eden, VanMeter, Rumsey, Maisog, Woods, & Zeffiro, 1996), electrophysiological (Lehmkuhle, Garzia, Turner, Hash, & Baro, 1993; Livingstone,

Rosen, Drislane, & Galaburda, 1991) and psychophysical experiments which suggest that disabled readers find it abnormally difficult to detect coherent motion in random dot kinematograms (Cornelissen, Richardson, Mason, & Stein, 1995), uniform field flicker (Brannan & Williams, 1988) and flickering sinewave gratings (Martin & Lovegrove, 1987; Mason, Cornelissen, Fowler, & Stein, 1993).

### *A magnocellular deficit in reading disability?*

One way to interpret results like these is to compare them with behavioural studies of macaques with specific lesions to the magno- or parvocellular visual pathways. The macaque's brain is thought to be sufficiently closely related to the human brain to justify applying anatomical and electrophysiological data from that species to human vision.

Subcortically, there exists a clear anatomical segregation between the outputs from M and P retinal ganglion cells whose axons target the magnocellular and parvocellular layers of the lateral geniculate nucleus (LGN). Livingstone and colleagues made histological comparisons of the LGN from five reading disabled and five normal brains (Livingstone *et al.*, 1991). The study revealed that the ventral, magnocellular layers of the LGN (mLGN) from the reading disabled brains contained fewer, smaller cells than the comparable layers in the normal brains. By contrast, no group differences were found in the cell sizes of the parvocellular layers of the

\*Psychology Department, Ridley Building, Newcastle University, Newcastle upon Tyne NE1 7RU, U.K.

†Mathematics and Statistics Department, Newcastle University, Newcastle upon Tyne NE1 7RU, U.K.

‡Physiology Department, Parks Road, Oxford OX1 3PT, U.K.

¶To whom all correspondence should be addressed [Fax: 0191 222 5622; Email: p.l.cornelissen@ncl.ac.uk].

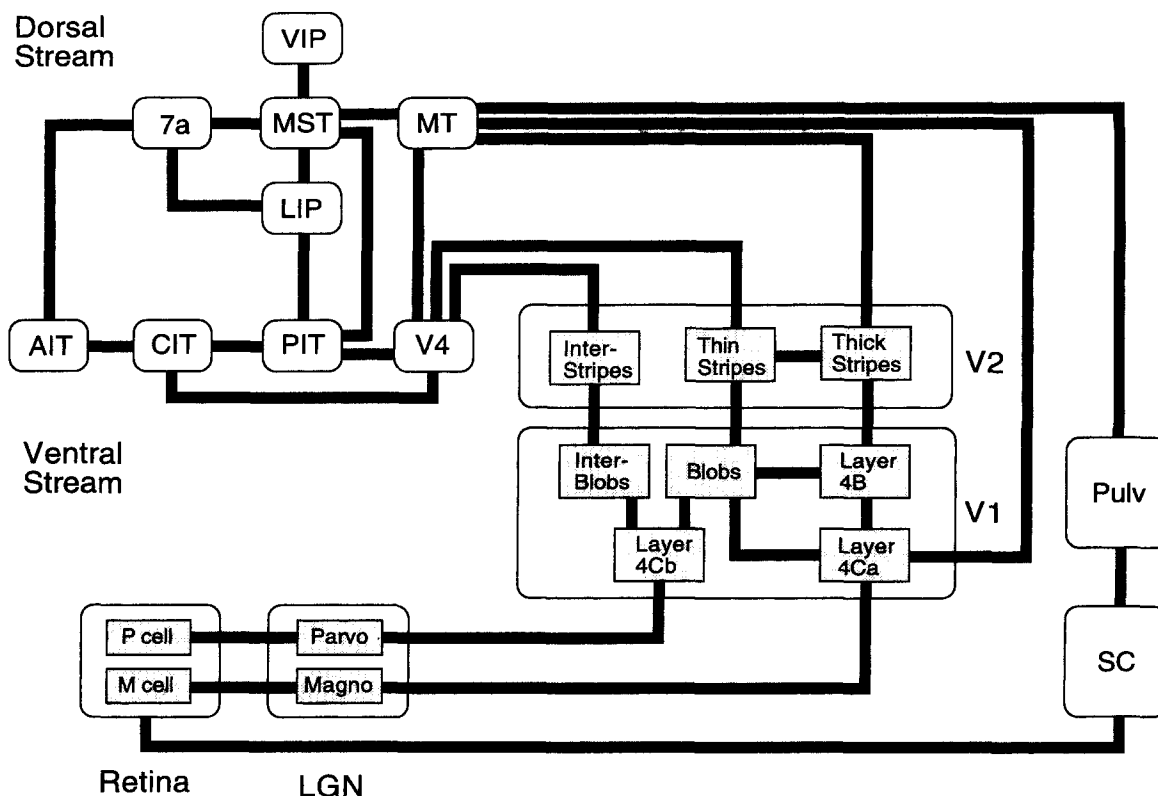

FIGURE 1. shows a schematic diagram of the two streams of visual processing in primate cerebral cortex. LGN, lateral geniculate nucleus; SC, superior colliculus; Pulv, pulvinar; PIT, posterior inferotemporal cortex; CIT, central inferotemporal cortex; AIT, anterior inferotemporal cortex; MT, middle temporal area; MST, middle superior temporal area; LIP, lateral intraparietal sulcus; VIP, ventral intraparietal sulcus. (Adapted from Milner & Goodale, 1995.)

LGN (pLGN). These findings suggested the existence of an anatomical abnormality of mLGN in reading disabled people. In macaques, lesions to mLGN (but not pLGN) cause a large decrease in luminance contrast sensitivity for stimuli of higher temporal frequency and lower spatial frequency (Merigan & Maunsell, 1993). They also produce motion-blind scotomata (Schiller, Logothetis, & Charles, 1990). Put together, these findings suggest that the reduced visual sensitivities of reading disabled individuals could be explained by a magnocellular system deficit which originates subcortically.

As Fig. 1 shows, while the anatomical segregation of magno- and parvo- streams from the LGN is maintained as far as the input layers of primary visual cortex (V1), the responses of cells beyond this point reflect the fact that information derived from M and P cells becomes increasingly mixed.

This has been shown convincingly by inactivation of either pLGN or mLGN combined with simultaneous single unit recordings in V1, and extra-striate MT and V4. Magno- rather than parvocellular blockade was more detrimental to MT neuronal responses, reflecting a predominant M input. However, blockade of both mLGN and pLGN affected the responses of cells in V1 and V4 about equally, indicating mixed M & P input (Maunsell, Nealey, & DePriest, 1990; see also Milner & Goodale, 1995 for review). In the face of such interaction, we asked whether reading disabled people might never-

theless show impairments in cortical visual functions which depend on M cell input (Cornelissen *et al.*, 1995). We exploited the fact that area MT has a predominant input from the magnocellular system, and that lesions of human MT (sometimes referred to as V5) cause akinetopsia, which is an inability to see movement (Zihl, von Cramon, & Mai, 1983). Single unit recordings in macaque have shown that neuronal responses in MT can account for monkeys' behavioural decisions during coherent motion detection tasks (Britten, Shadlen, Newsome, & Movshon, 1992; Shadlen, Britten, Newsome, & Movshon, 1996). Using photopic random dot displays, we found elevated motion coherence thresholds in groups of children and adults who were reading disabled compared with age-matched controls. Findings like these cannot pinpoint the anatomical origin of the magnocellular deficit in reading disabled people, but they do suggest that impaired magnocellular function does affect cortical visual processing (Walsh, 1995). Recently, a similar result was reported by Eden *et al.* (1996) using an fMRI technique.

As Walthermüller (1995) has pointed out with respect to the transient system, impaired magnocellular function could mean a number of different things physiologically. One possibility is that cell responses in the magnocellular system may be abnormally delayed (speed deficit). Their sensitivity might be changed for certain temporal frequencies resulting in an altered shape of the temporal

impulse–response function (temporal deficit). The magnocellular system could show abnormally small amplitude responses (energy deficit), or it could have reduced spatial resolution (spatial deficit). Since it is not possible to distinguish unambiguously between these possibilities, we will use the term magnocellular impairment to refer to degraded information processing in regions of the brain known to receive connections derived anatomically from M cells.

#### *Magnocellular system impairment and text perception*

The existence of an association between reading disability and impaired magnocellular function raises the possibility that failure of the visual system to process print correctly may contribute to some individuals' reading difficulties. We propose that when children read, impaired magnocellular function may lead to uncertainty about where letters and letter features are positioned with respect to each other, and that this leads to predictable reading errors. This hypothesis is consistent both with recent models of word recognition, as well as the suggestion that magnocellular input is likely to be important for encoding spatial position (Mishkin, Ungerlieder, & Macko, 1983; Milner & Goodale, 1995).

Current models of visual word recognition suggest that the early visual analysis of print makes available information not only about individual letter identity, but critically, letter position (Grainger & Dijkstra, 1995). Accordingly, the word "orange" can be considered as the ordered combination of its component letters, i.e. O + R + A + N + G + E. Evidence to support this view has come from letter-in-string detection tasks which have manipulated spatial redundancy or position-specific letter frequency (Mason, 1975; McClelland & Johnston, 1977). Position-specific letter frequency reflects the probability that a given letter will be present at a given position in a word of a given length. Thus, recognition of the word BLACK is facilitated by prior presentation of the prime stimulus BVK, which shares the same letters at the beginning and end of the letter string. However, the prime stimulus TBVKU fails to produce facilitation of this kind (Humphreys, Evett, & Quinlan, 1990). Grainger and Jacobs (1993) used a partial word-priming paradigm (e.g. "table" primed by TA%LE) to show that it is the positional frequencies of the letters maintained between prime and target (T, A, L and E, in the above example) that best predicts the size of the obtained priming effect. A potential problem with these experiments was the use of whole words as targets. It could be argued that priming effects attributed to low-level letter position encoding might simply reflect a top-down influence from whole words. To refute this criticism, Peressotti and Grainger (1995) used random consonant arrays in a "constituent letter priming task" (e.g. "FHK" primed by "hkf") to confirm the existence of priming effects which depend on letter position alone.

In this paper we suggest that impaired magnocellular function may degrade the encoding of letter position during reading. We envisage that positional uncertainty

of this kind could cause letters or parts of letters to be lost or duplicated, or even incorrectly bound together, leading to a scrambled or nonsense version of what is actually printed on the page. When children try to read aloud what they see under these circumstances, we predict that their utterances should contain sounds not represented in the printed word. We refer to such orthographically inconsistent reading errors as "letter" errors. Children commonly make other kinds of nonsense errors when reading (Gough & Walsh, 1991; Baldwin, 1990), but these "regularization" errors tend to be consistent with the printed orthography: they simply pronounce the words incorrectly (e.g. reading PERISH as PURR-ISH). We ignored errors of this kind. Finally, we ignored errors which were real word responses (e.g. reading MEMORY as MEMBER) on the grounds that there are too many potential explanations for them. For example, the child might have perceived the first three letters of "MEMORY" and used them as a cue to retrieve a more familiar word with the same stem.

In the present study, we used a coherent motion detection task to assess children's magnocellular function. We also measured the likelihood of children making "letter" errors in a single word reading task. If impaired magnocellular function does affect children's reading, then we should expect to find a positive correlation between motion coherence thresholds and children's "letter" errors.

## METHODS

### *Methodological issues*

In our previous study (Cornelissen *et al.*, 1995) we replicated two features commonly found in studies of visual processing and reading disability. First, subjects' performance on the motion detection task was very variable within the comparison groups. Second, even though the difference between mean thresholds for disabled readers and controls was significant, the two distributions overlapped considerably; there seemed to be a continuum of visual performance between reading disabled and control subjects. In the light of such variability, how should one test whether reduced sensitivity of this kind might affect reading? One way is to avoid comparing groups of reading disabled subjects with controls. Instead, we simply looked for a correlation between motion thresholds (magnocellular function) and the probability of children making "letter" errors in a sample of school children who had not been pre-selected in any way.

### *Subjects*

Sixty children were chosen from a Newcastle primary school to take part in this study. They represented all of the 34 boys and 26 girls in the two most senior classes of the school. Some of them were likely to have been reading disabled. The advantage in choosing such a sample is that the age range of these children was restricted, and they had been exposed to comparable

TABLE 1. Subject characteristics ( $n = 58$ )

Variable (units)	Mean range	(SD)
Chronological age (years: months)	10:5 9:4–11:5	(0:6)
Reading age (years: months)	9:11 6:5–14:5	(2:1)
Visual IQ (number correct/48)	27.9 11–42	(7.6)
Verbal IQ (quotient: 70–130)	96.8 83–118	(8.9)
Rhyme detection (PhAB) (number correct/21)	17.1 8–21	(3.2)
Spoonerism (PhAB) (number correct/40)	23.3 2–39	(9.7)
Motion detection (% coherence at threshold)	17.2 7.1–42.8	(8.4)
Letter errors made in experimental word lists (max = 45)	6.2 0–16	(4.3)
Total errors made in experimental word lists (max = 45)	19.2 8–34.5	(6.5)

teaching environments. Therefore, any bias which might be attributable to educational factors would have been consistent across all subjects. All children had normal or corrected-to-normal visual acuity. During the 3-month period over which the study was carried out, one boy transferred to another school and one girl was dropped from the study because of an ophthalmological problem which had yet to be diagnosed. The remaining 58 children completed all the psychological and visual tests and their characteristics are described in Table 1.

#### Psychological test battery

**IQ.** We used two group assessment measures of IQ; the AH1 X & Y Group Tests of Perceptual Reasoning (Heim, Watts & Simmonds, 1977) and the Non-Reading Intelligence Tests (NRIT), level 3 (Young, 1996). The AH1, X & Y, are parallel group tests of perceptual reasoning. The tests are non-verbal in the sense that the children need no words in which to express their answers and that slow readers or non-readers are not penalized. The problem-solving throughout is perceptual, as opposed to verbal or numerical. The AH1 raw scores can be converted into one of five age normed categories (e.g. in 10-year-olds, group A = 42–48, group B = 38–41, group C = 30–37, group D = 21–29 and group E = 0–19). Since the age range of our sample was restricted to 2 years, we have reported the raw scores for AH1 in Table 1 instead of the coarser grained age norm categories. (In our sample 50% of children fell into group C). The NRIT level 3 comprises four subtests. All of them are tests of verbal reasoning which do not require reading. An example question is: "What is made of wood, has four legs and is used for eating? swing, desk, table, plate". NRIT scores are converted into age normed quotients.

**Reading age.** Children's reading ages were assessed using the British Ability Scales (BAS) single word reading accuracy test.

**Phonological awareness.** We administered two subtests of the Phonological Awareness Battery (Educational Psychology Publishing, UCL, 1995). In the Rhyme Test, children are orally presented with three words and asked to identify which two end with the same sound (maximum score = 21). The Spoonerism Test consists of three parts. Part 1 (maximum score = 10) is a Semi-Spoonerisms measure where the child is asked to replace

the first sound of a word with a new sound (e.g. "cot" with a /g/ gives "got"). Part 2 (maximum score = 10) is also a Semi-Spoonerisms measure, but here the child replaces the first sound of the first word with the first sound of the second word (e.g. "die" with "pack" gives "pie"). Part 3 (maximum score = 20) is a full Spoonerisms measure, where the child is asked to exchange initial sounds in two words (e.g. "sad cat" gives "cad sat").

#### Experimental word list design and administration

At the beginning of each child's assessment, they were given the BAS single word reading test. Next, they were given an experimental word list selected on the basis of their BAS reading age. The choice of which experimental list to give was restricted to one of five possibilities, equivalent to five difficulty levels (level 1 is the easiest and level 5 the hardest). Each difficulty level corresponded to a bandwidth of the BAS reading age score. The word list for each difficulty level was designed so that children should make 30–50% errors. Each list comprised 45 regularly spelled words (the maximum number of letters and syllables in each word was 10 and 3, respectively). (Further details of the experimental word list design can be obtained from: Cornelissen, Bradley, Fowler, & Stein, 1991; Cornelissen, Bradley, Fowler, & Stein, 1992; Cornelissen, 1992.)

All children's responses were tape-recorded for later analysis, which was carried out by a scorer who was blind to their performance on the visual and psychological tests. The scorer listened for the *first complete utterance* in response to a target word; partial responses were ignored. Errors were subsequently classified as: real words, orthographically consistent nonsense errors, or orthographically inconsistent nonsense errors (i.e., the "letter" errors defined above). Again, these decisions were made without knowledge of children's performance on the motion task and the psychological tests. Examples of children's errors are shown in Table 2 below. Finally, the proportion of letter errors that each child made was

TABLE 2. Examples of children's reading errors

Error category	Target word	Error
Real word	fool	floor
	banker	blanket
	feeling	flooding
	contents	constant
	seduction	suggestion
Orthographically consistent nonsense error	leap	lep
	perish	purish
	fever	fevver
	wither	whyther
	prosper	pro-spur
Orthographically inconsistent nonsense "letter" error	victim	vikim
	garden	grandeem
	suspect	subpact
	temper	templay
	swift	sweef

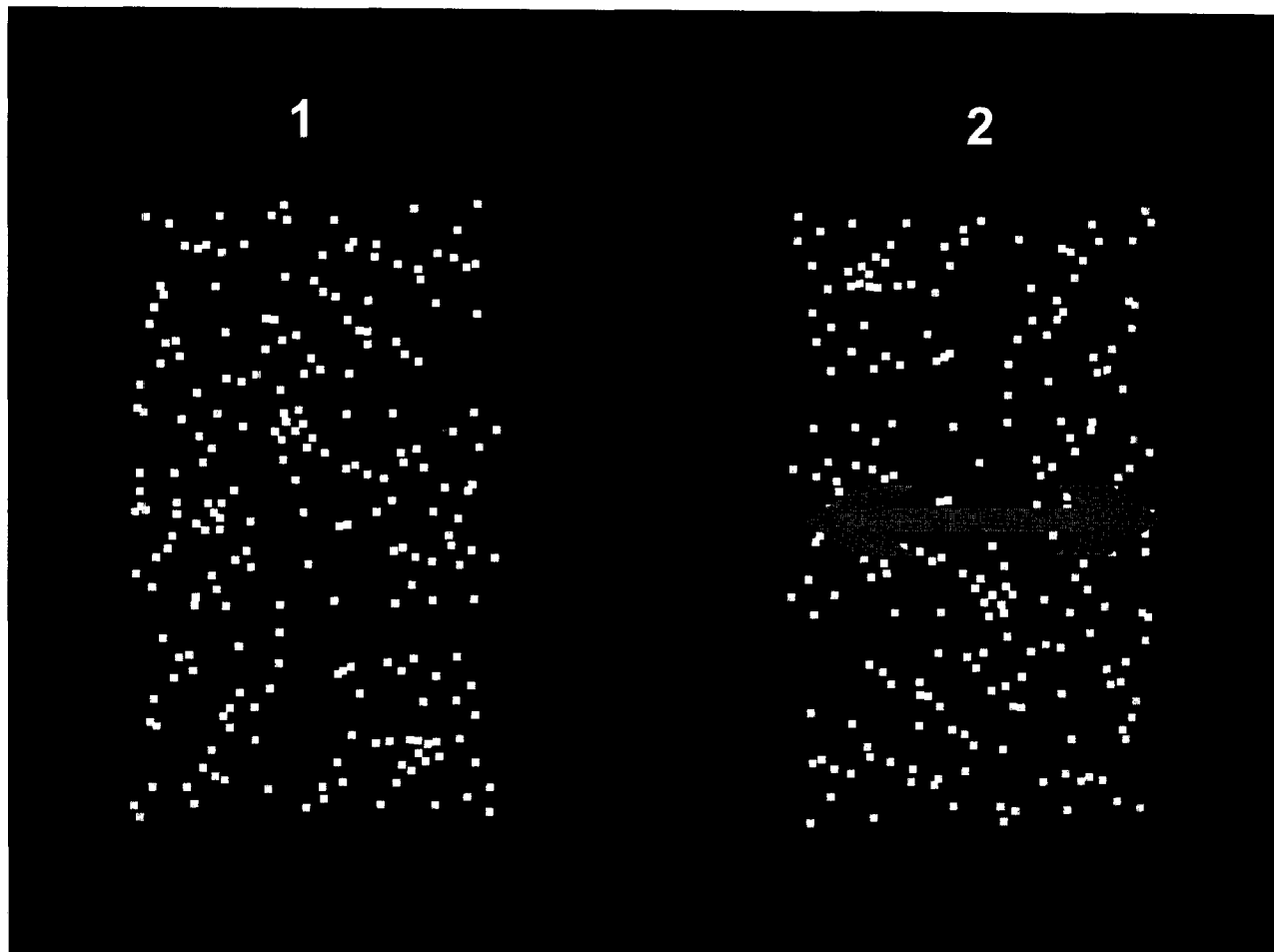

FIGURE 2. is a diagrammatic representation of both patches of the motion stimulus. In this example, patch 2 is shown with coherent side to side movement.

calculated, where  $p = \text{total number of letter errors} / \text{total number of errors}$ .

#### *Coherent motion thresholds*

Subjects sat 60 cm from an Iiyama Vision Master Pro-17 monitor (70 Hz vertical refresh) on which the random dot kinematograms were displayed. The stimuli were generated by a PC and comprised two rectangular patches, each containing 300 randomly arranged white dots on a dark background. At 60 cm each patch of dots subtended 8.8 deg by 12.4 deg. The patches were separated by a horizontal distance subtending 4.3 deg. The luminance of each white dot was 127.6 cd/m<sup>2</sup>, while the luminance of the darker background was set to 0.56 cd/m<sup>2</sup> (measured with an OptiCal digital photometer), giving a Michelson contrast of 99%. The room was illuminated by strip lights alone, producing a room illuminance of approximately 700 lux. The appearance of the stimuli is shown in Fig. 2.

On each trial, which lasted 2300 msec, coherent motion appeared randomly in one of the two patches. Coherently moving dots lived for only two consecutive animation frames (a total of 58 msec) before being reborn in a new, randomly selected position on the patch. Coherent dots moved at a speed of 15.1 deg/sec

horizontally, reversing direction every 580 msec. In both patches, noise dots were replotted on every animation frame (lasting 29 msec) at random positions.

We used a two-alternative forced-choice method (2AFC) to identify children's coherence thresholds. Coherence was varied according to a 1-up-1-down staircase procedure. The experimenter initiated each trial and subjects were asked to indicate which panel contained coherent motion either by pointing or by naming the side (labeled 1 or 2) on which it appeared. Once the experimenter keyed in each child's response, the next trial started automatically 1 sec later. Children were encouraged to make sure that they had looked carefully at both panels before they made their decision.

The staircase procedure started well above threshold at 90%. Coherence was then adaptively decreased by a factor of 1.122 for every correct response, and increased by a factor of 1.412 for every incorrect response. These two factors are equivalent to changes of 1 and 3 dB, respectively, where:

$$dB = 10 \cdot \text{Log}_{10}(\kappa)^2$$

where:  $\kappa = \% \text{ coherence}$ .

Every staircase procedure was run for a total of 10 reversals. Threshold was estimated as the geometric

TABLE 3. Pearson correlations between psychological measures, including motion detection

	Age	Reading ability	Non-verbal IQ	Verbal IQ	Rhyme detection	Spoonerism task	Motion detection
Age	—						
Reading ability	-0.018	—					
Non-verbal IQ	0.20	0.41**	—				
Verbal IQ	-0.23	0.36**	0.51***	—			
Rhyme detection	-0.12	0.40**	0.51***	0.44**	—		
Spoonerism task	-0.0098	0.57***	0.47***	0.42**	0.58***	—	
Motion detection	0.018	-0.19	-0.093	-0.28*	-0.064	-0.053	—

\* $P < 0.05$ ; \*\* $P < 0.005$ ; \*\*\* $P < 0.0005$ .

mean of the coherence levels at which the last eight reversals occurred. The geometric rather than the arithmetic mean was calculated to minimize the skewing effect of outlying data points. Children performed the entire procedure four times, so that we obtained a total of four thresholds for each subject. The first threshold was discarded as a learning period and the remaining three thresholds were averaged together for further analysis.

#### Statistical modelling of the data

We used multiple logistic regression to examine the relationship between the proportion of letter errors that children made and their motion detection thresholds, while controlling for any effect due to IQ, chronological age, reading ability and phonological awareness. The appropriate probability distribution for proportionate data is binomial because we were counting the number  $r$  of letter errors out of  $n$  events and calculating the proportion  $p = r/n$ . The variance of a proportion is  $p(1-p)/n$ , which depends upon the value of  $p$  for a given  $n$ ; it is largest when  $p = 0.5$  and smaller when  $p$  is near 0 or 1. In order to stabilize the variance in multiple regression analysis (see Altman, 1991) it is common to apply the logit (i.e., log odds) transform which is defined by:

$$\text{logit}(p) = \log_e \left( \frac{p}{1-p} \right)$$

where  $p = (\text{letter errors})/(\text{total errors})$ .

In logistic regression, the significance of each explanatory variable is assessed by comparing changes in scaled deviance (expressed as values of  $\text{Chi}^2$ ) between the full model and a model with the variable of interest removed. The regression coefficients were expressed as log odds ratios (i.e., logits), which were converted to odds ratios or risk values (i.e.  $p/1-p$ ). Odds ratios greater than 1 represent increased risk; values less than 1 represent reduced risk.

We carried out multiple regression analysis in two phases. In the first phase we included all explanatory variables in the linear model below to elucidate only those factors which had a significant effect on the proportion of letter errors that children made. The phase 1 model was: Model:

$$\log_e(p/1-p) =$$

$$b_1x_1 + b_2x_2 + b_3x_3 + b_4x_4 + b_5x_5 + b_6x_6 + b_7x_7$$

where:  $p = (\text{letter errors})/(\text{total error})$ ,  $x_1 = \text{chronological}$

age,  $x_2 = \text{reading age}$ ,  $x_3 = \text{non-verbal IQ}$ ,  $x_4 = \text{verbal IQ}$ ,  $x_5 = \text{rhyme detection}$ ,  $x_6 = \text{spoonerism task}$  and  $x_7 = \text{motion detection}$ .

In the second phase we explored a variety of methods to optimize a model which was built from the significant explanatory variables identified in phase 1.

## RESULTS

#### Univariate statistics

Approximately 10% of the children in this study had higher coherent motion thresholds than the worst reading disabled subject in our previous study (Cornelissen *et al.*, 1995). This is almost certainly due to the fact that the coherently moving dots in our earlier stimuli had infinite lifetime, compared with only two animation frames in the current stimuli. Thus, the motion detection task in the present study was more difficult.

Table 3 shows the matrix of Pearson correlations between the psychological measures. Motion detection is also included. As would be expected, we found significant positive correlations between reading ability, both IQ measures and both phonological awareness tasks. Motion detection did not correlate with any measure except for verbal IQ. We suggest that brighter children obtained lower coherent motion thresholds either because they learnt the task quicker, or because they were better able to discover optimal viewing strategies during the task.

Table 4 shows the correlations between the four estimates of children's motion detection thresholds.

Cronbach's Alpha for these data was calculated to be 0.82, suggesting an acceptable degree of reliability between the four estimates of motion detection threshold.

#### First phase of logistic regression modelling

Table 5 shows the output of the first regression model, described above.

TABLE 4. Correlations between the four estimates of motion detection threshold

	1 <sup>st</sup>	2 <sup>nd</sup>	3 <sup>rd</sup>	4 <sup>th</sup>
1 <sup>st</sup>	—			
2 <sup>nd</sup>	0.63*	—		
3 <sup>rd</sup>	0.72*	0.83*	—	
4 <sup>th</sup>	0.51*	0.67*	0.78*	—

\* $P < 0.0001$ .

TABLE 5. Output from first logistic regression model

Explanatory variable units	Regression coefficient (logit)	Standard error	Change in Chi <sup>2</sup> at 1 df	P value	Odds ratio/unit
Intercept	1.69	2.35	0.52	<i>P</i> > 0.1	—
Chronological age (months)	- 0.0057	0.015	0.15	<i>P</i> > 0.5	1.06
Reading age (months)	- 0.01	0.0039	6.38	<i>P</i> < 0.05	0.99
Non-verbal IQ number (correct/48)	0.056	0.11	0.24	<i>P</i> > 0.5	1.058
Verbal IQ (quotient)	- 0.0087	0.012	0.53	<i>P</i> > 0.1	0.991
Rhyme detection number (correct/21)	0.0048	0.033	0.021	<i>P</i> > 0.5	1.005
Spoonerism task number (correct/40)	0.019	0.011	4.13	<i>P</i> < 0.05	1.02
Motion detection (% coherence)	0.024	0.0093	6.89	<i>P</i> < 0.005	1.025

It is clear that the only factors which accounted for significant changes in Chi<sup>2</sup> were reading ability, phonological awareness measured by the spoonerism task and motion detection. The fact that there was no effect of rhyme detection when both phonological tasks were included in the same model is probably due to the high correlation between rhyme detection and the spoonerism task (see Table 3). Henceforth, chronological age, rhyme detection and both IQ measures are excluded from the analyses.

#### Second phase of logistic regression modelling

Figure 3(a, b, c) shows plots of the proportion of letter errors that children made as a function of motion detection, reading age and the spoonerism task, respectively. The proportionate data have been converted to empirical logits, which is a standard method for presenting such data (see Snedecor & Cochran, 1967). Empirical logits are given by:

$$\text{empirical logit} = \log_e \left( \frac{(t_1 + 0.5)}{(t_e - t_1) + 0.5} \right)$$

where:  $t_1$  = letter errors and  $t_e$  = total errors.

In order to illustrate the relationship between the original proportions of letter errors and the logit transforms of these proportions which were used in the regression analyses, we have included Fig. 3(d) which shows a plot of one against the other. (The slight scatter reflects the varying number of events,  $t_e$ ).

In support of our hypothesis, Fig. 3(a) shows that children who perform well on the motion detection task (i.e. low % coherence at threshold) made appropriately fewer letter errors than those who performed poorly at this task (i.e., high % coherence at threshold). However, this relationship is non-linear in that values of the empirical logit tend to asymptote above 20% coherence. Figure 3(b) also reveals a non-linear relationship between the proportion of letter errors and phonological awareness. This was caused by a small number of subjects who obtained either very low or very high scores on the spoonerism task, so that the empirical logit rises and then falls again as values along the  $x$ -axis increase.

In view of Fig. 3(a, b) we felt we should take these non-linearities into account when optimizing the final model. However, there is a very large number of functions which could, in principle, be used to achieve this. Since our analysis was *post hoc* and exploratory, we chose the

simplest approach possible, which was to include second-order terms (see Altman, 1991). There appears to be little justification in the physiological or psychological literature for fitting a more complex function. The second phase regression model is shown below: Model:

$$\log_e(p/1-p) =$$

$$b_1x_1 + b_2x_2 + b_3x_3 + b_4x_4 + b_5x_5 + b_6x_6$$

where:  $p$  = (letter errors)/(total error),  $x_1$  = reading age,  $x_2$  = spoonerism,  $x_3$  = motion detection,  $x_4$  = (reading age)<sup>2</sup>,  $x_5$  = (spoonerism)<sup>2</sup> and  $x_6$  = (motion detection)<sup>2</sup>.

We included the three explanatory variables which survived the first phase above: reading ability, the spoonerism task and coherent motion detection. To account for the non-linearities shown in Fig. 3, we then added the squared terms: (reading ability)<sup>2</sup>, (spoonerism task)<sup>2</sup> and (motion detection)<sup>2</sup>. We then used the logistic procedure in SAS (SAS Institute Inc., Cary, NC, U.S.A.) for model fitting.

We first compared the residual scaled deviance for the polynomial model above using all the variables  $x_1 \dots x_6$  (residual Chi<sup>2</sup> = 46.69 at 51 df) with a linear model which excluded variables  $x_4 \dots x_6$  (residual Chi<sup>2</sup> = 64.47 at 54 df). The difference in residual Chi<sup>2</sup> of 17.78 at 3 df between the two models is significant at  $P < 0.0005$  and strongly supports the inclusion of the quadratic terms. We then explored a variety of different methods for rejecting or retaining explanatory variables including: fitting of the complete model, backward elimination, forward selection and stepwise selection. As a measure of goodness of fit, SAS calculates the residual scaled deviance per degrees of freedom (Chi<sup>2</sup>/df); a value near 1 indicates that the remaining variation in the data can reasonably be attributed to the fact that the outcome is a binary random variable which takes integer values. The four different fitting procedures described above gave Chi<sup>2</sup>/df values of 0.96, 0.98, 1.13 and 1.13, respectively, indicating some unexplained variation. However, since there was little to choose between them, we have reported the simplest model in full below:

$$\log_e(p/(1-p)) =$$

$$-0.37 + 0.11.x_1 + 0.04.x_2 - 0.0027.x_3 - 0.0019.x_4$$

where:  $p$  = (letter errors)/(total errors),  $x_1$  = spoonerism task,  $x_2$  = motion detection,  $x_3$  = (spoonerism task)<sup>2</sup>,  $x_4$  = (motion detection)<sup>2</sup>.

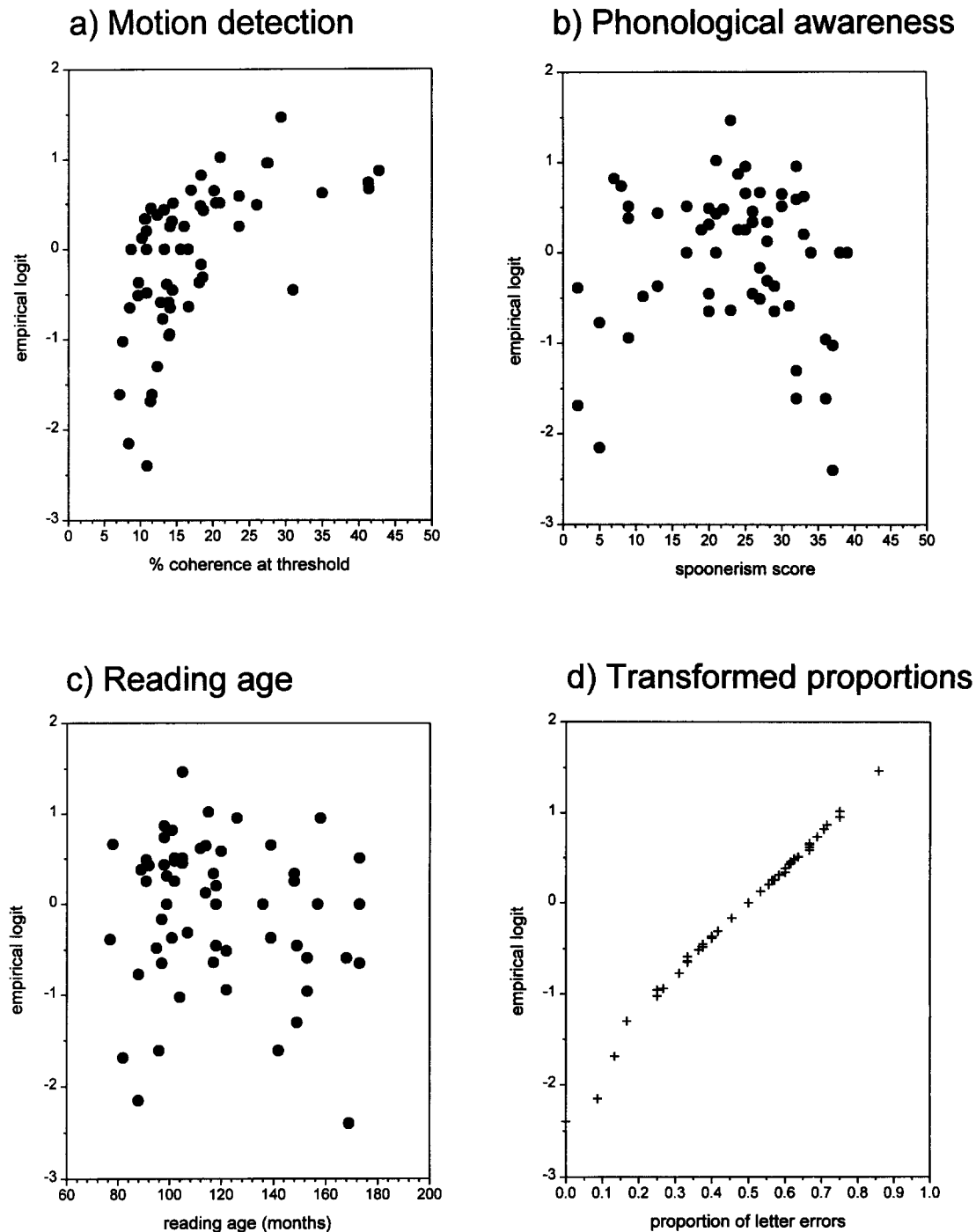

FIGURE 3. Scatter plots of the relationship between the transformed proportion of letter errors (empirical logit) and (a) motion detection (% coherence at threshold), (b) phonological awareness (spoonerism task) and (c) reading age. (d) Shows the relationship between the original proportions of letter errors that children made and their empirical logit transforms. See main text for details.

The regression coefficients, their  $\chi^2$  values and associated significance levels are given in Table 6.

We should emphasize that the equation above represents the best statistical description of our data that we could produce. To illustrate this model, in Fig. 4 we have plotted the probability of the occurrence of letter errors ( $z$ -axis) as a function of both phonological awareness ( $x$ -axis) and motion detection ( $y$ -axis).

Probability values are calculated from logits such that:

if  $l = \text{logit}(p)$ , then  $p = e^l / (1 + e^l)$ . Figure 4 shows that the likelihood of letter errors increases sharply with poorer performance on the motion task, but the rate of increase tails off above 20% coherence. The effect of phonological awareness (spoonerism task) is clearly non-linear; the chances of children making letter errors are highest in children with *intermediate* phonological skills, but markedly reduced in children with either very poor or very good phonological skills. It should be emphasized,



TABLE 6. Output from second logistic regression model

Explanatory variable units	Regression coefficient (logit)	Standard error	Change in Chi <sup>2</sup> at 1 df	P value	Odds ratio/unit
Intercept	-0.37	0.37	0.99	$P > 0.1$	—
Spoonerism task number (correct/40)	0.11	0.036	9.21	$P < 0.005$	1.12
Motion detection (% coherence)	0.041	0.0090	20.26	$P < 0.0005$	1.042
(Spoonerism task) <sup>2</sup> (number correct/40)	-0.0027	0.00095	7.97	$P < 0.005$	0.997
(Motion detection) <sup>2</sup> (% coherence)	-0.0019	0.00088	4.50	$P < 0.05$	0.998

however, that the non-linear relationship between letter errors and phonological skills is caused in our data by a small number of children who obtained extreme scores on the spoonerism task. Therefore, further samples of children would be required to confirm this finding.

#### Exclusion of reading disabled subjects

In the current study, we tested an unselected sample of primary school children on the grounds that our previous study (Cornelissen *et al.*, 1995) suggested a continuum of performance at coherent motion detection. Therefore, if our sample was representative of school children at large, it should have contained anywhere between 5 and 15% of reading disabled individuals. To exclude the possibility that our results depended exclusively on such individuals, we carried out one final analysis. We defined as "reading disabled", anyone whose reading age was 2 or more years

below their chronological age and eliminated them (c.f. Williams, May, Solman, & Zhou, 1995). Even when these 17 "reading disabled" individuals were excluded, we still found that both motion detection thresholds and spoonerism task scores were significantly correlated with the proportion of letter errors that children made ( $r = 0.56$ ,  $P < 0.0005$ ;  $r = -0.36$ ,  $P = 0.01$ , respectively). The fact that the correlation between letter errors and the spoonerism task became negative when "reading disabled" individuals were excluded (as opposed to the non-linear relationship for the whole sample) suggests strongly that it was these very individuals who had some of the worst phonological skills, as would be predicted. A *T*-test comparison between the spoonerism scores obtained by "reading disabled" and "normals" confirmed this (mean scores: 15.8 and 26.5, respectively;  $T_{56} = -4.34$ ,  $P < 0.0005$ ).

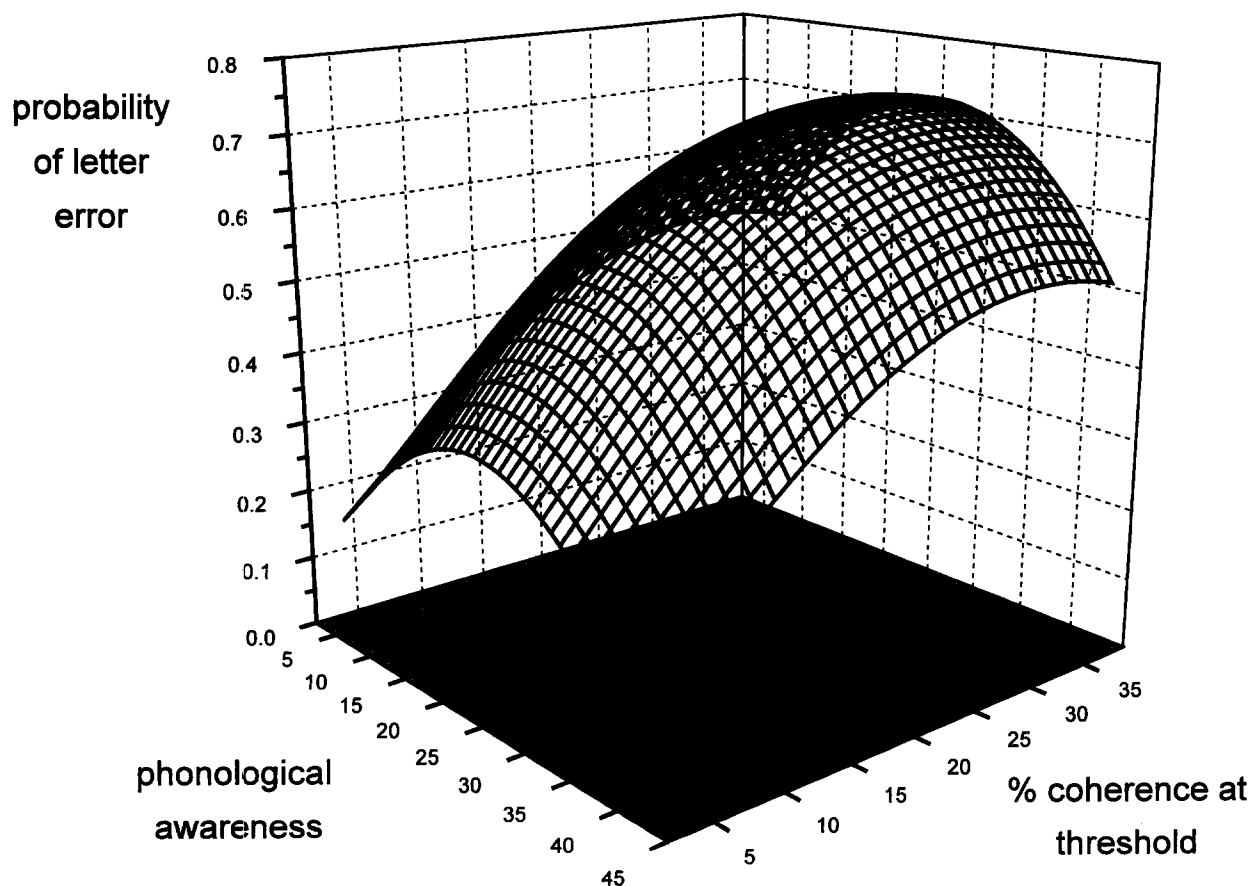

FIGURE 4. 3-D surface plot in which the probability of the occurrence of letter errors (z-axis) is shown as a function of both phonological awareness (x-axis) and motion detection (y-axis). See main text for details.

## DISCUSSION

We propose that impairment of the visual magnocellular system, revealed by poor performance on a motion detection task, could degrade the encoding of the position of letter features when children read. Consequently we predicted that children with high motion detection thresholds would be more likely to make orthographically inconsistent nonsense ("letter") errors than children with low motion thresholds. In support of our hypothesis, we found a positive relationship, albeit a non-linear one, between children's motion detection thresholds and the likelihood of them making letter errors. This result held when chronological age, IQ, reading age and phonological awareness were taken into account. Moreover, the major effects we found persisted even when "reading disabled" children were removed from the sample, consistent with a continuum of performance relating variation in magnocellular function to variation in reading behaviour.

Intriguingly, we found that phonological factors also played an important part in explaining children's "letter" errors. Those individuals with intermediate phonological skills (assessed by the spoonerism task) were much more likely to make letter errors than children who had either very poor or very good phonological skills. Since there was no correlation between children's motion detection thresholds and their performance on the phonological tasks (see Table 3), this effect must have been independent of magnocellular function and requires a separate explanation.

Gough and Walsh (1991) and Baldwin (1990) have described how children can make nonsense errors for phonological reasons alone. This is easily predicted if we consider a child who misapplies letter-sound conversion rules. For example, if asked to read the word "PERISH", they may accurately identify two graphemic units, i.e. "PER-" and "-ISH". But they might incorrectly translate the first unit as "PURR", leading to the nonsense error "PURRISH". This kind of error is consistent with the printed orthography and was deliberately excluded from our analysis. However, children who apply letter-sound conversion rules imperfectly, and who would arguably be the same children who had intermediate scores in the spoonerism task, may also make "letter" errors for phonological reasons. For example, when such a child sees "PERISH", they may associate at least one letter/letter-cluster with an incorrect sound/sound-cluster; e.g. mistaking /p/ for /b/, giving "BERRISH" or mistaking /l/ for /E/ giving "PERESH". According to our definition, since either response would constitute a "letter" error, such a mechanism could certainly account for children making some "letter" errors for phonological reasons. By contrast, children with the highest scores on the spoonerism task may have such good phonological skills that they can apply letter-sound correspondences faultlessly and thus would not make this kind of mistake. At the opposite extreme, children who score particularly poorly on the spoonerism task may not yet have developed the kind of analytical strategy which, when

applied incorrectly, could lead to phonologically based "letter" errors; in this respect their reading skills may be comparable to Frith's logographic stage of reading development (Frith, 1985).

At this point in the discussion we have accounted for children's "letter" errors in terms of variable magnocellular function. Yet, we have also suggested that children's "letter" errors might be explained in terms of their phonological skills. So have we created a dilemma? We propose an explanation which reconciles these two suggestions in a complementary way.

### *Multiple-level models of reading*

The visual analysis of print makes available orthographic information at a variety of scales from single letters (see Introduction) to syllables (Prinzmetal, Treiman, & Rho, 1986; Treiman & Zukowski, 1988). Yet, in order that words can be read aloud, this multi-scale orthographic activity must be associated with appropriate phonological output. Shallice, Warrington, and McCarthy (1983) proposed a solution to this problem in which multiple parallel correspondences are allowed between orthographic and phonological units of varying sizes. Their scheme comprised seven levels: initial consonant clusters, vowels, syllable-final consonant clusters, initial cluster plus vowel, rimes, syllables and morphemes. Recently, this "multiple-levels" approach has been successfully implemented in artificial neural network models of reading aloud (Norris, 1994; Brown, 1987). Since orthographic units are directly connected to phonological units in parallel, it is plausible that distortion at either the orthographic or the phonological ends of these connections could have similar effects. Thus, while the presence of magnocellular impairment need not necessarily be associated with a phonological deficit in the same individual—i.e., the two can be independent of each other—nevertheless, the effects of damage in either domain could produce the same errors in letter/letter-cluster to sound/sound-cluster mapping; both could lead to children making letter errors. Clearly, while ideas like these are consistent with the present findings, further experiments are required to test them. In particular, it would be interesting to try to dissociate phonological from visual effects, perhaps by manipulating the spelling-sound regularity of target words (see Adams, 1990; Hyönä & Olson, 1995). In addition, we need to find a direct way of assessing the putative relationship between magnocellular function and positional encoding of letter features.

### *Reading disability and M stream deficits*

The correlational design of this study and the nature of the subject sample, make it difficult to relate our findings directly to the comparison between reading disabled and normal children. Nevertheless, it is possible to offer some speculations. A key observation is the continuum of visual performance between reading disabled and control subjects. This finding is reminiscent of Seymour's (Seymour, 1986) serial case studies of reading disabled

and control subjects. It suggests that many of the component skills in reading are distributed continuously in the population. If we accept this idea, children's reading problems can be considered within the following information processing framework. Let us assume, for the sake of simplicity, that reading can be described by a multi-channel model in which, for example, visual processing, phonological processing and short-term memory are necessary components. The amount of information which can flow through each channel can vary continuously between a minimum and maximum value. Since reading requires several channels, the net flow of information through the model can be described by some function of these channels (linear or otherwise). If an individual's information processing capacity falls below some critical value, then they may experience difficulty with reading. In this view, a critical reduction in information flow could either be caused by a restriction within a single channel, or by a variable combination of restrictions across two or more channels. Clearly, this model avoids the problem of forcing a division between phonological and visual impairments when trying to explain children's reading problems; it allows variable contributions from several factors in different individuals and is consistent with the inter-relationships we found between motion detection and phonological awareness in primary school children.

In conclusion, we have identified a novel association which suggests that variation in magnocellular function is correlated with the pattern of children's reading errors when they read regularly spelled words. We have also shown that while the magnitude of this effect depends on children's phonological skills, these two factors seem to be independent of each other—in this sample of children at least. The framework we have suggested to interpret our results has the advantage that it is open to further experimental testing.

## REFERENCES

- Adams, M. J. (1990). *Beginning to read*. Cambridge, MA: MIT Press.
- Altman, D. G. (1991). *Practical statistics for medical research*. London: Chapman and Hall.
- Baldwin, S. (1990). Reading skills and special needs: survey of recent research. In Jones, N. (Ed.), *Special educational needs review: integration and pupil skills*. Vol. 3, Part IV, Chapter 14, pp. 202–214. London, New York: The Falmer Press.
- Bradley, L. & Bryant, P. E. (1983). Categorising sounds and learning to read—a causal connection. *Nature*, *301*, 419–421.
- Brady, S. A. & Shankweiler, D. P. (Eds) (1991). *Phonological processes in literacy*. Hillsdale, NJ: Lawrence Erlbaum.
- Brannan, J. & Williams, M. C. (1988). The effects of age and reading ability on flicker threshold. *Clinical Vision Science*, *32*, 137–142.
- Britten, K. H., Shadlen, M. N., Newsome, W. T. & Movshon, J. A. (1992). The analysis of visual motion: a comparison of neuronal and psychophysical performance. *Journal of Neuroscience*, *12*, 4745–4765.
- Brown, G. D. A. (1987). Resolving inconsistency. A computational model of word naming. *Journal of Memory and Language*, *26*, 1–23.
- Cornelissen, P. L., Richardson, A. J., Mason, A. J. & Stein, J. F. (1995). Contrast sensitivity and coherent motion detection measured at photopic luminance levels in dyslexics and controls. *Vision Research*, *35*(10), 1483–1494.
- Cornelissen, P. L., Bradley, L., Fowler, M. S. & Stein, J. F. (1991). What children see affects how they read. *Developmental Medicine and Child Neurology*, *33*, 755–762.
- Cornelissen, P. L., Bradley, L., Fowler, M. S. & Stein, J. F. (1992). Covering one eye affects how some children read. *Developmental Medicine and Child Neurology*, *34*, 296–304.
- Cornelissen, P. L. (1992). D. Phil. Thesis, University of Oxford.
- Eden, G. F., VanMeter, J. W., Rumsey, J. M., Maisog, J. M., Woods, R. P. & Zeffiro, T. A. (1996). Abnormal processing of visual motion in dyslexia revealed by functional brain imaging. *Nature*, *382*, 66–70.
- Frith, U. (1985). Beneath the surface of developmental dyslexia. In Patterson, K. E., Marshall, J. C. & Coltheart, M. (Eds), *Surface dyslexia*. London: Routledge & Kegan Paul.
- Gough, P. B. & Walsh, M. A. (1991). Chinese, Phoenician and the orthographic cipher of English. In Brady, S. & Shankweiler, D. (Eds), *Phonological processes in literacy*. Hillsdale, NJ: Lawrence Erlbaum.
- Grainger, J. & Dijkstra, T. (1995). Visual word recognition. In Dijkstra, A. & Smedt, K. (Eds), *Computational psycholinguistics: symbolic and subsymbolic models of language processing*. U.K.: Harvester Wheatsheaf.
- Grainger, J. & Jacobs, A. M. (1993). Masked partial word priming in visual word recognition: Effects of positional letter frequency. *Journal of Experimental Psychology: Human Perception and Performance*, *19*, 951–964.
- Heim, A. W., Watts, K. P. & Simmonds, V. (1977) *The AHI X & Y group tests of perceptual reasoning*. NFER-NELSON.
- Humphreys, G. W., Evett, L. J. & Quinlan, P. T. (1990). Orthographic processing in visual word identification. *Cognitive Psychology*, *22*, 517–560.
- Hyönä, J. & Olson, R. K. (1995). Eye fixation patterns among dyslexic and normal readers: effects of word length and word frequency. *Journal of Experimental Psychology: Learning, Memory and Cognition*, *21*(6), 1430–1440.
- Lehmkühle, S., Garzia, R. P., Turner, L., Hash, T. & Baro, J. A. (1993). A defective visual pathway in children with reading disability. *New England Journal of Medicine*, *328*(14), 989–996.
- Livingstone, M. S., Rosen, G. D., Drislane, F. W. & Galaburda, A. (1991). Physiological and anatomical evidence for a magnocellular deficit in developmental dyslexia. *Proceedings of the National Academy of Sciences USA*, *88*, 7943–7947.
- Martin, F. & Lovegrove, W. (1987). Flicker contrast sensitivity in normal and specifically disabled readers. *Perception*, *16*, 215–221.
- Mason, M. (1975). Reading ability and letter search time: Effects of orthographic structure defined by single-letter positional frequency. *Journal of Experimental Psychology: General*, *104*, 146–166.
- Mason, A. J., Cornelissen, P. L., Fowler, M. S. & Stein, J. F. (1993). Static and flicker contrast sensitivity in children with unstable visual direction sense. *Clinical Vision Science*, *84*, 345–353.
- Maunsell, J. H. R., Nealey, T. A. & DePriest, D. D. (1990). Magnocellular and parvocellular contributions to responses in the Middle Temporal Visual Area (MT) of the macaque monkey. *Journal of Neuroscience*, *10*(10), 3323–3334.
- McClelland, J. L. & Johnston, J. C. (1977). The role of familiar units in perception of words and nonwords. *Perception and Psychophysics*, *22*, 249–261.
- Merigan, W. H. & Maunsell, J. H. R. (1993). How parallel are the primate visual pathways? *Annual Review of Neuroscience*, *16*, 369–402.
- Milner, D. A. & Goodale, M. A. (1995). *The visual brain in action*. Oxford: Oxford University Press.
- Mishkin, M., Ungerlieder, L. G. & Macko, K. A. (1983) Object vision and spatial vision: two cortical pathways. *Trends in Neuroscience*, October, pp. 414–417.
- Norris, D. (1994). A quantitative multiple levels model of reading aloud. *Journal of Experimental Psychology: Human Perception and Performance*, *20*, 1212–1232.
- Peressotti, F. & Grainger, J. (1995). Letter-position coding in random consonant arrays. *Perception and Psychophysics*, *57*(6), 875–890.
- Prinzmetal, W., Treiman, R. & Rho, S. H. (1986). How to see a reading unit. *Journal of Memory and Language*, *25*, 461–475.

- Rutter, M. & Yule, W. (1975). The concept of specific reading retardation. *Journal of Child Psychology and Psychiatry*, 16, 181–197.
- Schiller, P. H., Logothetis, N. K. & Charles, E. R. (1990). Role of the colour-opponent and broad-band channels in vision. *Visual Neuroscience*, 5, 321–346.
- Seymour, P. H. K. (1986). *Cognitive analysis of dyslexia*. London: Routledge & Kegan Paul.
- Shadlen, M. N., Britten, K. H., Newsome, W. T. & Movshon, J. A. (1996). A computational analysis of the relationship between neuronal and behavioral-responses to visual-motion. *Journal of Neuroscience*, 16, 1486–1510.
- Shallice, T., Warrington, K. E. & McCarthy, R. (1983). Reading without semantics. *Quarterly Journal of Experimental Psychology*, 35, 111–138.
- Snedecor, G. W. & Cochran, W. G. (1967). *Statistical methods*. Iowa: Iowa State University Press.
- Snowling, M. J. (1980). The development of grapheme–phoneme correspondences in normal and dyslexic readers. *Journal of Experimental Child Psychology*, 29, 294–305.
- Treiman, R. & Zukowski, A. (1988). Units in reading and spelling. *Journal of Memory and Language*, 27, 466–477.
- Walsh, V. (1995). Reading between the laminae. *Current Biology*, 511, 1216–1217.
- Walthermüller, P. U. (1995). Is there a deficit of early vision in dyslexia? *Perception*, 248, 919–936.
- Williams, M. C., May, J. G., Solman, R. & Zhou, H. (1995). The effects of spatial filtering and contrast reduction on visual search times in good and poor readers. *Vision Research*, 352, 285–291.
- Willows, D. M., Kruk, R. S. & Corcos, E. (Eds) (1993). *Visual processes in reading and reading disabilities*. London: Lawrence Erlbaum.
- Young, D. (1996). *Non-reading intelligence tests*. London: Hodder & Stoughton.
- Zihl, J., von Cramon, D. & Mai, N. (1983). Selective disturbance of movement vision after bilateral brain damage. *Brain*, 106, 313–340.

---

*Acknowledgements*—This work was supported by funds awarded by the Royal Society, the Orton Dyslexia Society and the Research Committee of Newcastle University.